

**BT 50**

TROWAL Cutlery Drier / Polisher

BT 50

Despite of most modern dish washing technology, knives, forks and spoons do not often leave the dish washer really dry and stain-free. The result: You cannot do without time and personal intensive reworking measures.

Walther Trowal, specialist for surface technologies, attended to this problem and elaborated a perfect, economic solution:

The cutlery drier BT 50 dries and polishes up to 12,000 cutlery parts per hour and provides high-gloss and hygienically acceptable results.

Functionality

Heated-up, vibrating drying granulate gently and perfectly polishes and dries the cutlery parts. It passes through a spiral shaped work bowl, which is filled with heated and sterilized drying granulate. The cutlery, completely surrounded by the drying media is so gently dried and polished. In the separation zone, your cutlery is separated from the drying granulate and is transferred into the provided cutlery basket.

Ease of use

The operation is child's play. The compact design is designated by little space requirement, optimum functionality and maximum profitability. Simple, hygienic cleaning, the degree of automation, facilitated loading and unloading of the cutlery parts as well as the use of top quality, wear-protected materials are further advantages!



Special features

- **High cutlery throughput:** The spacious work bowl guarantees a significant cutlery throughput of up to 8.000 parts per hour with a gentle parts transport.
- **Facilitated, hygienic cleaning:** by opening the cover of the drier, a simple and quick cleaning is possible. Work bowl and outer lining are, for hygienic reasons, completely made of stainless steel.
- **High sterility of the granulate:** Due to the increased temperature of the granulate of more than 70°C, the uptake of humidity is ameliorated, thus keeping the granulate permanently free from bacteria.
- **New heating technology:** Short heating times and high temperature stability as well as an effective heat transfer from the bottom of the work bowl into the drying granulate result in little energy requirement.
- **Low noise level:** The quiet running < 70 dB(A), the little space requirement and the mobility by rollers allow the flexible use in every scullery.
- **Direct load of filled cutlery baskets:** The cutlery can comfortably be filled into the loading funnel directly from the dish washer baskets with out contamination by manual handling.
- **Facilitated handling:** Simple two-button-operation. The operator is informed about the state of process by means of two coloured lamps, therefore, operating errors are nearly excluded.
- **Drying granulate:** The low dust special drying medium "GTM 300" is sterilized according to DIN EN 1174, part 1 – 3, tested by GfPS, Aachen (laboratory no. 23036M068)

Type	BT 50
Dimensions [mm] L x B x H	1000 x 940 x 1000
Motor power [kW]	0,3
Max. heating performance [kW]	1,2
E-consumption [kWh]	1,5
Voltage [V]	220 V - 50 Hz
Weight, empty [kg]	290
Operating weight [kg]	308
Throughput	max. 8.000
Noise level operation dB[A]	< 70

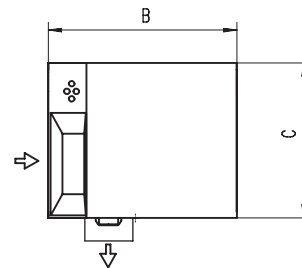
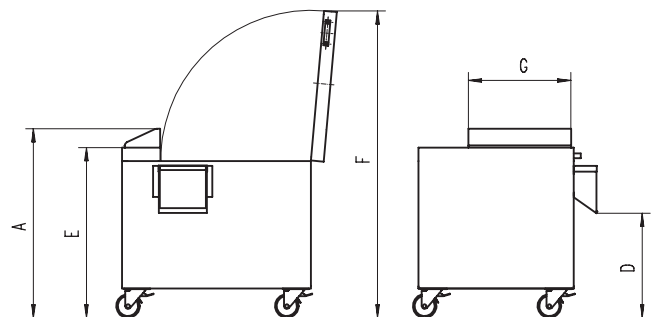

A	B	C	D	E	F	G
1000	1000	820	550	900	1630	540

Dimensions (in mm)